



**CUNOVA**

FORMERLY KME  
SPECIAL PRODUCTS  
& SOLUTIONS



**CuNi 90/10 and CuNi 70/30  
OSNA-10 & OSNA-30  
Shipbuilding**



**MARITIME  
APPLICATIONS**

## CONTENT

<b>The Company</b>	03
The Material	04
Shipbuilding - Product Range	07
<b>Pipes</b>	08
<b>Butt Welding Fittings</b>	
Elbows	10
Tee Pieces (equal and reduced)	14
End Caps	20
Saddle Type Connections	22
Reducers (concentric and eccentric)	28
<b>Flanges</b>	
Welding Necks	34
Outer Flanges	36
Composite Blind Flanges	38
<b>Brazing Fittings</b>	
Couplings (straight and reduced)	40
Elbows	44
Tee Pieces (equal and reduced)	46
End Caps	48
Male Connectors (straight)	50
Female Connectors (straight)	52
<b>Miscellaneous</b>	
Hexagon Head Screw Plugs	54
Welding Ends	55
Sockets	56
Unions	58
Male Unions (reduced)	60
<b>cunova Quality Management</b>	63

## The Company

cunova's corporate goal is to develop and manufacture products that meet customer demands, finding solutions for their specific applications, and providing services as a long-term partner. cunova's strategy for accomplishing this goal is based on a highly skilled and experienced workforce. cunova has the ability to invent and develop new materials and innovative production processes via ongoing advancement and training of our employees and the continual improvement of its organisational structures.

### Maritime Applications

cunova GmbH business unit Maritime Applications is specialized in the production of copper-nickel alloys for piping systems in shipbuilding, offshore installations and other maritime applications. The sea and its atmosphere is one of the most corrosive environments on the earth. Seagoing vessels need large amounts of seawater daily for

The materials used for seawater piping systems therefore must be highly resistant to pitting, crevice and erosion corrosion as well as stress corrosion cracking and macrofouling. Moreover such materials must satisfy high standards in terms of hot and cold working properties and weldability.

- fire water systems
- sprinkler systems
- cooling systems
- ballast systems



# CUNOVA

# The Material

## cunova Alloys OSNA®-10 and OSNA®-30

For decades, seawater pipe systems made of copper-nickel alloys have been put to successful use on seagoing vessels and offshore production units like platforms, drilling rigs, semi-submersibles FPSOs etc.

The chemical composition of OSNA®-10 (CuNi 90/10) and OSNA®-30 (CuNi 70/30) copper-nickel alloys have been modified so that they meet the requirements of all the main international standards (see tables below). Reduced tolerance limits for certain impurities moreover provide for an enhanced cold workability and weldability of cunova's alloy.

## Main Advantages of OSNA®-10 and OSNA®-30

Despite the rough conditions in maritime service and the highly corrosive nature of seawater, the products provide well balanced combination of technical and economical advantages:

- Simple alloying system with good weldability
- Excellent ductility and toughness
- Good erosion corrosion resistance
- Resistant to uniform and localised corrosion
- No effect of ambient seawater temperatures
- No effect of seawater chlorination
- Resistant to biofouling
- Resistant to stress-corrosion cracking
- Low maintenance costs
- A lot of design experience

## Comparison of Standard Specifications for OSNA®-30 (CuNi 70/30)

	cunova Alloy OSNA®-30 (CuNi 70/30)	EN 1652 / 12420 / 12449 CW354H	MIL-T-16420K ASTM B 466 / 467 <sup>1</sup> C 71520
Ni %	30.0 - 32.0	30.0 - 32.0	29.0 - 33.0
Fe %	0.6 - 1.0	0.4 - 1.0	0.4 - 1.0
Mn %	0.5 - 1.0	0.5 - 1.5	max. 1.0
C %	max. 0.04	max. 0.05	max. 0.05
Pb %	max. 0.01	max. 0.02	max. 0.02
S %	max. 0.02	max. 0.05	max. 0.02
P %	max. 0.01	max. 0.02	max. 0.02
Zn %	max. 0.20	max. 0.50	max. 0.50
Sn %	-	max. 0.05	-
other imp.	max. 0.30	max. 0.20	-
Cu %	rem.	rem.	min. 65

<sup>1</sup>equal to C 71500 for subsequent welding

## Comparison of Standard Specifications for OSNA®-10 (CuNi 90/10)

	cunova Alloy OSNA®-10 (CuNi 90/10)	EN 1652 / 12420 / 12449 CW352H	DIN 86019 WL 2.1972	EEMUA 234, 2016, UNS 7060X	MIL-T-16420K ASTM B 466 / 467 C 70620
Ni %	10.0 - 11.0	9.0 - 11.0	9.0 - 11.0	10.0 - 11.0	9.0 - 11.0
Fe %	1.5 - 1.8	1.0 - 2.0	1.5 - 1.8	1.5 - 2.0*	1.0 - 1.8
Mn %	0.6 - 1.0	0.5 - 1.0	0.5 - 1.0	0.5 - 1.0	max. 1.0
C %	max. 0.02	max. 0.05	max. 0.05	max. 0.05	max. 0.05
Pb %	max. 0.01	max. 0.02	max. 0.01	max. 0.01	max. 0.02
S %	max. 0.005	max. 0.05	max. 0.005	max. 0.02	max. 0.02
P %	max. 0.02	max. 0.02	max. 0.02	max. 0.02	max. 0.02
Zn %	max. 0.05	max. 0.50	max. 0.05	max. 0.20	max. 0.50
Sn %	max. 0.03	max. 0.03	-	-	-
other imp.	max. 0.20	max. 0.20	max. 0.20	max. 0.30	-
Cu %	rem.	rem.	rem.	rem.	min. 86.5

<sup>1</sup>equal to C 70600 for subsequent welding

\*The iron content has been specified to improve corrosion resistance



OSNA®-10/30 SHIPBUILDING

## Product Range

OSNA®-10 and OSNA®-30 seawater pipes	OSNA®-10 (CuNi 90/10)	OSNA®-30 (CuNi 70/30)
Manufactured in two configurations: <ul style="list-style-type: none"> <li>• seamless</li> <li>• seamwelded</li> </ul>	6 mm (0.2") – 457 mm (18") O.D. seamless, up to 1200 mm (48") O.D. seamwelded	6 mm (0.2") – 323.9 mm (12.8") O.D. seamless, up to 1200 mm (48") O.D. seamwelded
	International Standards <ul style="list-style-type: none"> <li>• EN 1652/12420/12449</li> <li>• DIN 86019</li> <li>• EEMUA 234 (2016)</li> <li>• ASTM-B-466/467</li> <li>• MIL-T-16420 K</li> <li>• DEF STAN 02-878 (NES 779)</li> </ul>	International Standards <ul style="list-style-type: none"> <li>• EN 1652/12420/12449 (CW354H)</li> <li>• ASTM-B-466/467</li> <li>• MIL-T-16420 K</li> <li>• DEF STAN 02-878</li> </ul>

cunova offers a comprehensive range of pipes and fittings in different sizes and dimensions for seawater piping systems in different applications. Furthermore, we are also offering sheets and plates in different sizes.



# Pipes

**Specifications:**

DIN 86019, DIN EN 12449  
Seamwelded DIN 86018

**Material:**

OSNA®-10 (CuNi 90/10) and  
OSNA®-30 (CuNi 70/30)

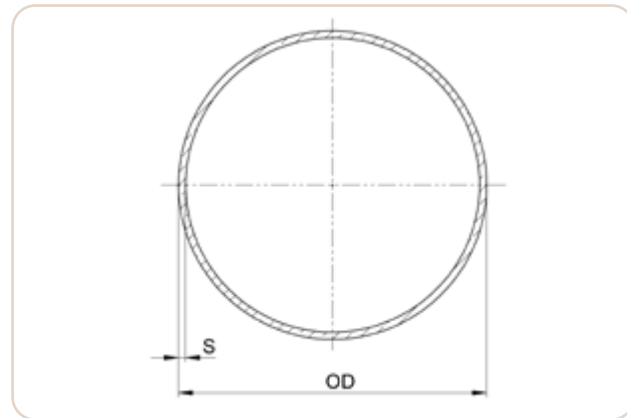

## Seamless Pipe

Size			Wall Thickness			
NPS	DN	OD mm	Standard		Special*	
			S	kg/m	S	kg/m
	4	8.0	1.0	0.20		
1/8	6	10.0	1.0	0.25		
1/4	8	12.0	1.0	0.31		
3/8	12	16.0	1.0	0.42	1.5	0.61
1/2	16	20.0	1.0	0.53	1.5	0.78
3/4	20	25.0	1.5	0.99	2.0	1.29
1	25	30.0	1.5	1.20	2.0	1.57
1 1/4	32	38.0	1.5	1.53	2.0	2.01
1 1/2	40	44.5	1.5	1.80	2.0	2.38
2	50	57.0	1.5	2.33	2.0	3.08
2 1/2	65	76.0	2.0	4.14	2.5	5.14
3	80	98.0 (88.9)	2.0	4.87	2.5	6.09

\*For offshore wall thickness see separate catalogue.

## Seamless Pipe

Size			Wall Thickness			
NPS	DN	OD mm	Standard		Special*	
			S	kg/m	S	kg/m
4	100	108	2.5	7.37	3.0	8.84
5	125	133	2.5	9.12	3.0	10.94
6	150	159	2.5	10.9	3.0	13.08
7	175	194	3.0	16.0		
8	200	219 (219.1)	3.0	18.12	3.5	21.12
10	250	267	3.0	22.13	4.0	29.47
12	300	324 (323.9)	4.0	35.80	5.0	44.75
14	350	368	4.0	40.70	5.5	55.96
16	400	419	4.0	46.40	6.0	69.60
18	450	457	4.5	56.91		

\*For offshore wall thickness see separate catalogue.

## Seamwelded Pipe

Size			Wall Thickness	
NPS	DN	OD mm	Standard	
			S	kg/m
20	500	508	5	70.32
24	600	610	5	84.56
28	700	711	6	118.28
32	800	813	6	135.38
36	900	914	8	202.66

Other dimensions on request.

BUTT WELDING FITTINGS

# Elbows - Long Radius 1.5 D

**Specifications:**  
DIN 86090

**Material:**  
OSNA®-10 – copper-nickel

**Type and Construction:**

Elbows for pipes up to and including 20"/ 508 mm in size are normally supplied seamless. Elbows for larger diameter pipes are made from half shells, longitudinally welded. 45° and 90° elbows are available in all sizes.

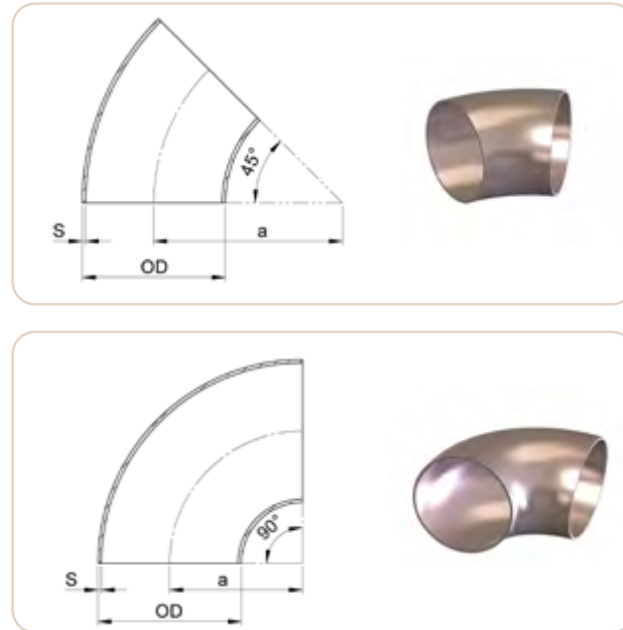

**Seamless Pipe**

Size			Wall Thickness	Radius	~e	Theoretical Weight	
NPS	DN	OD mm				S mm	a mm
1/2	16	20.0	1.0	25.0	10.4	0.013	0.026
3/4	20	25.0	1.5	27.5	11.4	0.029	0.058
1	25	30.0	1.5	33.5	14.0	0.035	0.07
1 1/4	32	38.0	1.5	45.0	19.0	0.06	0.12
1 1/2	40	44.5	1.5	51.0	21.0	0.07	0.15
2	50	57.0	1.5	72.0	30.0	0.14	0.29
2 1/2	65	76.0	2.0	95.0	39.0	0.34	0.69
3	80	89.0	2.0	114.5	47.0	0.47	0.95

Size			Wall Thickness	Radius	~e	Theoretical Weight	
NPS	DN	OD mm				S mm	a mm
4	100	108	2.5	142.5	59	0.90	1.80
5	125	133	2.5	181.0	75	1.45	2.90
6	150	159	2.5	216.0	89	2.30	4.60
7	175	194	3.0	270.0	112	4.05	8.10
8	200	219	3.0	305.0	126	4.55	9.10
10	250	267	3.0	378.0	157	7.70	15.40
12	300	324	4.0	457.0	189	13.00	26.00
14	350	368	4.0	533.5	221	21.00	42.00
16	400	419	4.0	609.5	252	29.50	59.00
18	450	457	4,5	686.0	284	36.00	72.00
20	500	508	5.0	762.0	316	45.00	90.00
24	600	610	5.0	914.0	379	60.00	120.00
28	700	711	6.0	1,067	442	99.00	190.90
32	800	813	6.0	1,219	505	129.50	259.00
36	900	914	8.0	1,372	568	220.00	440.00

Other dimensions on request.

# Elbows - Short Radius 1.0 D

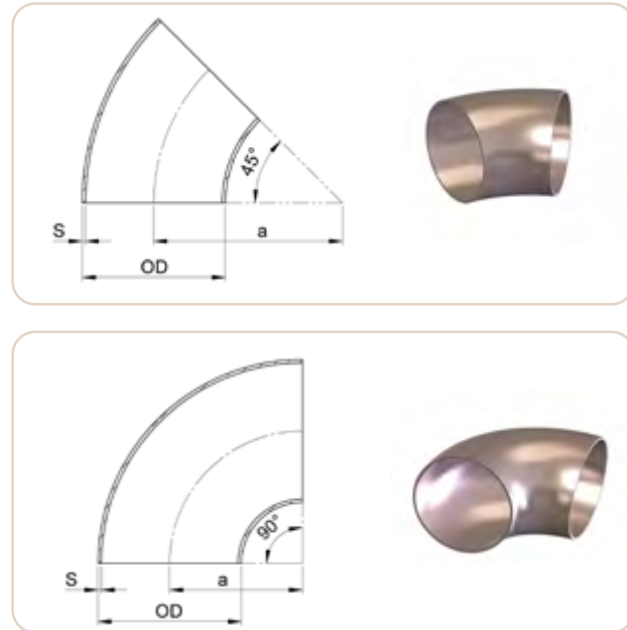

Size			Wall Thickness	Radius	~e	Theoretical Weight	
NPS	DN	OD mm				S mm	a mm
						45°	90°
1	25	30.0	1.5	30.0	12	0.024	0.049
1¼	32	38.0	1.5	32.5	14	0.039	0.078
1½	40	44.5	1.5	40.0	17	0.057	0.110
2	50	57.0	1.5	52.5	22	0.960	0.192
2½	65	76.0	2.0	70.0	29	0.215	0.430
3	80	89.0	2.0	82.5	34	0.295	0.590
4	100	108.0	2.5	100.0	41	0.600	1.210
5	125	133.0	2.5	125.0	52	0.900	1.850

Size			Wall Thickness	Radius	~e	Theoretical Weight	
NPS	DN	OD mm				S mm	a mm
						45°	90°
6	150	159	2.5	150	62	1.30	2.65
7	175	194	3.0	180	75	2.27	4.54
8	200	219	3.0	210	87	2.92	5.85
10	250	267	3.0	255	106	4.46	8.89
12	300	324	4.0	305	126	8.67	17.34
14	350	368	4.0	352.5	146	11.49	22.99
16	400	419	4.0	400	166	14.92	29.85
18	450	457	4.5	457	189	20.61	41.23
20	500	508	5.0	508	210	28.31	56.61
24	600	610	5.0	610	253	40.80	81.60
28	700	711	6.0	711	295	66.50	133.05
32	800	813	6.0	813	337	87.00	174.00
36	900	914	8.0	914	379	6.61	293.23

Other dimensions on request.

BUTT WELDING FITTINGS

# Tee Pieces, equal

**Specifications:**  
DIN 86088

**Material:**  
OSNA®-10 – copper-nickel

**Type and Construction:**  
Tees for pipes up to and including 8" / 219 mm are normally supplied as one-piece and seamless.

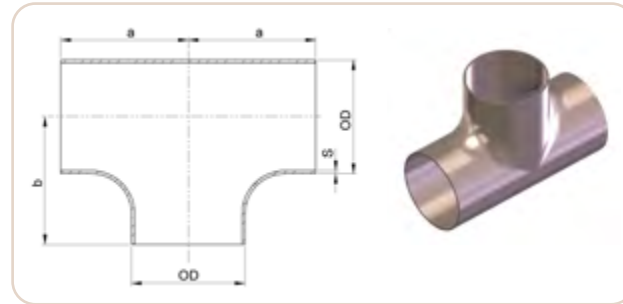

Size			Wall Thickness	Size		Theoretical Weight
NPS	DN	OD mm	S mm	a mm	b mm	kg /piece
½	16	20	1.0	25	25	0.11
¾	20	25	1.5	29	29	0.14
1	25	30	1.5	38	38	0.19
1¼	32	38	1.5	48	48	0.37
1½	40	44.5	1.5	57	57	0.56
2	50	57	1.5	64	64	0.72
2½	65	76	2.0	76	76	1.25
3	80	89	2.0	86	86	1.74
4	100	108	2.5	105	105	2.94
5	125	133	2.5	124	124	4.01
6	150	159	2.5	143	143	5.25
8	200	219	3.0	178	178	11.60
10	250	267	3.0	216	216	14.92

Size			Wall Thickness	Size		Theoretical Weight
NPS	DN	OD mm	S mm	a mm	b mm	kg /piece
12	300	324	4.0	254	254	21.30
14	350	368	4.0	279	279	25.90
16	400	419	4.0	305	305	33.40
18	450	457	4.5	343	343	48.60
20	500	508	5.0	381	381	63.20
24	600	610	5.5	432	432	93.80

Other dimensions on request.

BUTT WELDING FITTINGS

# Tee Pieces, reduced

**Specifications:**  
DIN 86088

**Material:**  
OSNA®-10 – copper-nickel

**Type and Construction:**  
Tees for pipes up to and including 8" / 219 mm are normally supplied as one-piece and seamless.

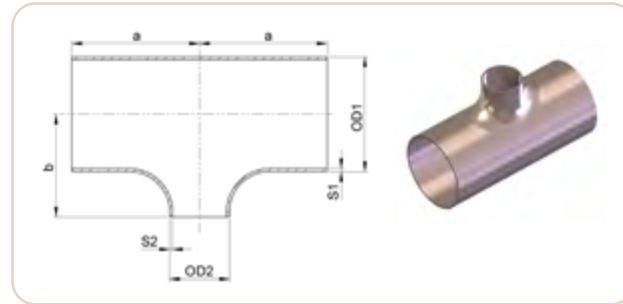

Size			Wall Thickness				Theoretical Weight	
NPS	DN	OD <sub>1</sub> mm	OD <sub>2</sub> mm	S <sub>1</sub> mm	S <sub>2</sub> mm	a mm	b mm	kg / piece
¾ x ½	20 x 16	25 x 20		1.5 x 1.0		29	26	0.08
1 x ½	25 x 16	30 x 20		1.5 x 1.0		38	29	0.15
1 x ¾	25 x 20	30 x 25		1.5 x 1.5		38	35	0.20
1¼ x ½	32 x 16	38 x 20		1.5 x 1.0		36	36	0.32
1¼ x ¾	32 x 20	38 x 25		1.5 x 1.5		48	35	0.36
1¼ x 1	32 x 25	38 x 30		1.5 x 1.5		48	42	0.38
1½ x ¾	40 x 20	44.5 x 25		1.5 x 1.5		57	40	0.48
1½ x 1	40 x 25	44.5 x 30		1.5 x 1.5		57	45	0.53
1½ x 1¼	40 x 32	44.5 x 38		1.5 x 1.5		57	51	0.59
2 x 1	50 x 25	57 x 30		1.5 x 1.5		64	51	0.66
2 x 1¼	50 x 32	57 x 38		1.5 x 1.5		64	57	0.74
2 x 1½	50 x 40	57 x 44.5		1.5 x 1.5		64	63	0.76
2½ x 1	65 x 25	76 x 30		2.0 x 1.5		76	56	1.01
2½ x 1¼	65 x 32	76 x 38		2.0 x 1.5		76	62	1.08

Size			Wall Thickness				Theoretical Weight	
NPS	DN	OD <sub>1</sub> mm	OD <sub>2</sub> mm	S <sub>1</sub> mm	S <sub>2</sub> mm	a mm	b mm	kg / piece
2½ x 1½	65 x 40	76 x 44.5		2.0 x 1.5		76	71	1.05
2½ x 2	65 x 50	76 x 57		2.0 x 1.5		76	73	1.05
3 x 1¼	80 x 32	89 x 38		2.0 x 1.5		86	73	1.32
3 x 1½	80 x 40	89 x 44.5		2.0 x 1.5		86	76	1.40
3 x 2	80 x 50	89 x 57		2.0 x 1.5		86	80	1.36
3 x 2½	80 x 65	89 x 76		2.0 x 2.0		86	83	1.65
4 x 1½	100 x 40	108 x 44.5		2.5 x 1.5		105	89	2.40
4 x 2	100 x 50	108 x 57		2.5 x 1.5		105	90	2.49
4 x 2½	100 x 65	108 x 76		2.5 x 2.0		105	92	2.43
4 x 3	100 x 80	108 x 89		2.5 x 2.0		105	96	2.39
5 x 2	125 x 50	133 x 57		2.5 x 1.5		124	98	3.66
5 x 2½	125 x 65	133 x 76		2.5 x 2.0		124	105	3.35
5 x 3	125 x 80	133 x 89		2.5 x 2.0		124	108	3.36
5 x 4	125 x 100	133 x 108		2.5 x 2.5		124	117	3.43
6 x 2½	150 x 65	159 x 76		2.5 x 2.0		143	118	4.51
6 x 3	150 x 80	159 x 89		2.5 x 2.0		143	121	4.72
6 x 4	150 x 100	159 x 108		2.5 x 2.5		143	130	4.47
6 x 5	150 x 125	159 x 133		2.5 x 2.5		143	136	5.00
8 x 4	200 x 100	219 x 108		3.0 x 2.5		178	156	8.97
8 x 5	200 x 125	219 x 133		3.0 x 2.5		178	162	9.00
8 x 6	200 x 150	219 x 159		3.0 x 2.5		178	168	9.03



## Tee Pieces, reduced (continued)

Size			Wall Thickness				Theoretical Weight	
NPS	DN	OD <sub>1</sub> mm	OD <sub>2</sub>	S <sub>1</sub> mm	S <sub>2</sub> mm	a mm	b mm	kg / piece
10 x 5	250 x 125	267 x 133		3.0 x 2.5		216	189	9.88
10 x 6	250 x 150	267 x 159		3.0 x 2.5		216	194	10.40
10 x 7	250 x 175	267 x 194		3.0 x 3.0		216	198	11.82
10 x 8	250 x 200	267 x 219		3.0 x 3.0		216	203	13.85
12 x 6	300 x 150	324 x 159		4.0 x 2.5		254	219	18.27
12 x 7	300 x 175	324 x 194		4.0 x 3.0		254	222	19.00
12 x 8	300 x 200	324 x 219		4.0 x 3.0		254	229	19.92
12 x 10	300 x 250	324 x 267		4.0 x 3.0		254	241	20.31
14 x 7	350 x 175	368 x 194		4.0 x 3.0		279	242	23.50
14 x 8	350 x 200	368 x 219		4.0 x 3.0		279	248	24.10
14 x 10	350 x 250	368 x 267		4.0 x 3.0		279	257	24.80
14 x 12	350 x 300	368 x 324		4.0 x 4.0		279	270	25.40
16 x 8	400 x 200	419 x 219		4.0 x 3.0		305	276	30.10
16 x 10	400 x 250	419 x 267		4.0 x 3.0		305	283	30.50

Size			Wall Thickness				Theoretical Weight	
NPS	DN	OD <sub>1</sub> mm	OD <sub>2</sub>	S <sub>1</sub> mm	S <sub>2</sub> mm	a mm	b mm	kg / piece
16 x 12	400 x 300	419 x 324		4.0 x 4.0		305	295	31.80
16 x 14	400 x 350	419 x 368		4.0 x 4.0		305	305	32.50
18 x 10	450 x 250	457 x 267		4.5 x 3.0		343	310	41.70
18 x 12	450 x 300	457 x 324		4.5 x 4.0		343	321	43.20
18 x 14	450 x 350	457 x 368		4.5 x 4.0		343	330	43.70
18 x 16	450 x 400	457 x 419		4.5 x 4.0		343	330	46.20
20 x 12	500 x 300	508 x 324		5.0 x 4.0		381	347	57.70
20 x 14	500 x 350	508 x 368		5.0 x 4.0		381	356	58.40
20 x 16	500 x 400	508 x 419		5.0 x 4.0		381	356	59.20
20 x 18	500 x 450	508 x 457		5.0 x 4.5		381	368	60.70
24 x 14	600 x 350	610 x 368		5.0 x 4.0		432	393	84.50
24 x 16	600 x 400	610 x 419		5.0 x 4.0		432	406	85.50
24 x 18	600 x 450	610 x 457		5.0 x 4.5		432	419	86.90
24 x 20	600 x 500	610 x 508		5.5 x 5.0		432	432	89.40

# End Caps

**Specifications:**  
DIN 28011

**Material:**  
OSNA®-10 – copper-nickel

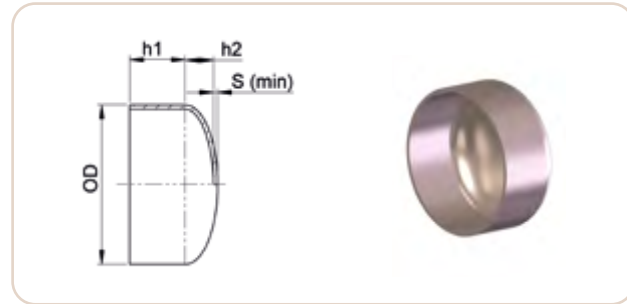

Size						Theoretical Weight
NPS	DN	OD mm	S mm	h <sub>1</sub> mm	h <sub>2</sub> mm	kg / piece
1	25	30.0	1.5	15	5	0.03
1 ¼	32	38.0	1.5	15	7	0.05
1 ½	40	44.5	1.5	15	8	0.06
2	50	57.0	1.5	20	10	0.10
2 ½	65	76.0	2.0	20	14	0.20
3	80	89.0	2.0	20	16	0.26
4	100	108.0	2.5	20	20	0.45
5	125	133.0	2.5	20	25	0.63
6	150	159.0	2.5	20	29	0.85
7	175	194.0	3.0	20	36	1.45
8	200	219.0	3.0	20	41	1.79

Size						Theoretical Weight
NPS	DN	OD mm	S mm	h <sub>1</sub> mm	h <sub>2</sub> mm	kg / piece
10	250	267	3.0	20	50	2.56
12	300	324	4.0	20	61	4.82
14	350	368	4.0	20	69	6.15
16	400	419	4.0	20	79	7.83
18	450	457	4.5	20	86	10.36
20	500	508	5.0	20	96	14.05
24	600	610	5.0	20	116	19.89
28	700	711	6.0	25	135	32.65
32	800	813	6.0	25	155	42.16
36	900	914	8.0	35	173	72.65

Other dimensions on request.

BUTT WELDING FITTINGS

# Saddle Type Connections

**Specifications:**  
DIN 86087

**Material:**  
OSNA®-10 – copper-nickel

**Dimensions:**  
To suit appropriate header and branch pipe diameters and thicknesses.

**Type and Construction:**  
Saddles for pipes up to and including 14"/ 368 mm are normally supplied as one-piece and seamless.

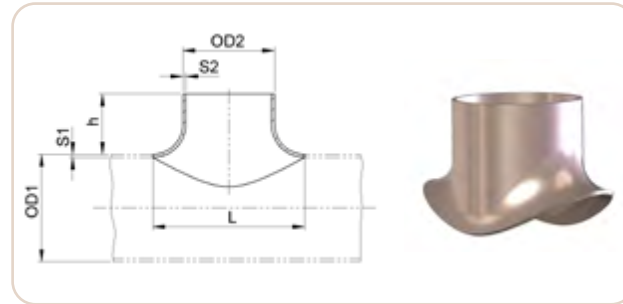

Size			Wall Thickness		Height	Length	Theoretical Weight	
NPS	DN	OD <sub>1</sub> mm	OD <sub>2</sub> mm	S <sub>1</sub> mm	S <sub>2</sub> mm	h mm	L mm	kg / piece
½ x ½	16 x 16	20 x 20		1 x 1		20	32	0.05
¾ x ½	20 x 16	25 x 20		1.5 x 1.0		20	40	0.06
¾ x ¾	20 x 20	25 x 25		1.5 x 1.5		22	40	0.07
1 x ¾	25 x 20	30 x 25		1.5 x 1.5		22	40	0.08
1 x 1	25 x 25	30 x 30		1.5 x 1.5		30	50	0.09
1¼ x 1	32 x 25	38 x 30		1.5 x 1.5		30	50	0.10
1¼ x 1¼	32 x 32	38 x 38		1.5 x 1.5		35	64	0.11
2½ x 1¼	40 x 32	44.5 x 38		1.5 x 1.5		35	64	0.14
1½ x 1½	40 x 40	44.5 x 44.5		1.5 x 1.5		35	74	0.15
2 x 1¼	50 x 32	57 x 38		1.5 x 1.5		35	64	0.15
2 x 1½	50 x 40	57 x 44.5		1.5 x 1.5		35	74	0.17

Size		Wall Thickness		Height	Length	Theoretical Weight		
NPS	DN	OD <sub>1</sub> mm	OD <sub>2</sub> mm	S <sub>1</sub> mm	S <sub>2</sub> mm	h mm	L mm	kg / piece
2 x 2	50 x 50	57 x 57		1.5 x 1.5		40	97	0.25
2½ x 1¼	65 x 32	76 x 38		2.0 x 1.5		35	64	0.34
2½ x 1½	65 x 40	76 x 44.5		2.0 x 1.5		35	74	0.30
2½ x 2	65 x 50	76 x 57		2.0 x 1.5		40	97	0.52
2½ x 2½	65 x 65	76 x 76		2.0 x 2.0		50	126	0.48
3 x 1¼	80 x 32	89 x 38		2.0 x 1.5		35	64	0.36
3 x 1½	80 x 40	89 x 44.5		2.0 x 1.5		35	74	0.44
3 x 2	80 x 50	89 x 57		2.0 x 1.5		40	97	0.56
3 x 2½	80 x 65	89 x 76		2.0 x 2.0		50	126	0.55
3 x 3	80 x 80	89 x 89		2.0 x 2.0		55	149	0.76
4 x 1¼	100 x 40	108 x 44.5		2.5 x 1.5		35	74	0.32
4 x 2	100 x 50	108 x 57		2.5 x 1.5		40	97	0.40
4 x 2½	100 x 65	108 x 76		2.5 x 2.0		50	126	0.65
4 x 3	100 x 80	108 x 89		2.5 x 2.0		55	149	0.79
4 x 4	100 x 100	108 x 108		2.5 x 2.5		75	188	1.30

# Saddle Type Connections (continued)

**Specifications:**  
DIN 86087

**Material:**  
OSNA®-10 – copper-nickel

**Dimensions:**  
To suit appropriate header and branch pipe diameters and thicknesses.

**Type and Construction:**  
Saddles for pipes up to and including 14"/ 368 mm are normally supplied as one-piece and seamless.

Size				Wall Thickness		Height	Length	Theoretical Weight
NPS	DN	OD <sub>1</sub> mm	OD <sub>2</sub>	S <sub>1</sub> mm	S <sub>2</sub> mm	h mm	L mm	kg / piece
5 x 2	100 x 50	133 x 57		2.5 x 1.5		40	97	0.40
5 x 2 ½	125 x 65	133 x 76		2.5 x 2.0		50	126	0.80
5 x 3	125 x 80	133 x 89		2.5 x 2.0		55	149	1.00
5 x 4	125 x 100	133 x 108		2.5 x 2.5		75	188	1.20
5 x 5	125 x 125	133 x 133		2.5 x 2.5		85	233	1.70
6 x 2 ½	150 x 65	159 x 76		2.5 x 2.0		50	126	0.65
6 x 3	150 x 80	159 x 89		2.5 x 2.0		55	149	1.00
6 x 4	150 x 100	159 x 108		2.5 x 2.5		75	188	1.20
6 x 5	150 x 125	159 x 133		2.5 x 2.5		85	233	2.00
6 x 6	150 x 150	159 x 159		2.5 x 2.5		95	279	2.60
7 x 2 ½	175 x 65	194 x 76		3.0 x 2.0		50	126	1.20
7 x 3	175 x 80	194 x 89		3.0 x 2.0		55	149	1.30

Size				Wall Thickness		Height	Length	Theoretical Weight
NPS	DN	OD <sub>1</sub> mm	OD <sub>2</sub>	S <sub>1</sub> mm	S <sub>2</sub> mm	h mm	L mm	kg / piece
7 x 4	175 x 100	194 x 108		3.0 x 2.5		75	188	1.40
7 x 5	175 x 125	194 x 133		3.0 x 2.5		85	233	1.90
7 x 6	175 x 150	194 x 159		3.0 x 2.5		95	279	2.50
7 x 7	175 x 175	194 x 194		3.0 x 3.0		110	334	3.20
8 x 3	200 x 80	219 x 89		3.0 x 2.0		55	149	1.30
8 x 4	200 x 100	219 x 108		3.0 x 2.5		75	188	1.80
8 x 5	200 x 125	219 x 133		3.0 x 2.5		85	233	2.70
8 x 6	200 x 150	219 x 159		3.0 x 2.5		95	279	3.80
8 x 7	200 x 175	219 x 194		3.0 x 3.0		110	334	4.50
8 x 8	200 x 200	219 x 219		3.0 x 3.0		125	379	5.70
10 x 4	250 x 100	267 x 108		3.0 x 2.5		75	188	1.85
10 x 5	250 x 125	267 x 133		3.0 x 2.5		85	233	2.35
10 x 6	250 x 150	267 x 159		3.0 x 2.5		95	279	3.70
10 x 7	250 x 175	267 x 194		3.0 x 3.0		110	334	4.70
10 x 8	250 x 200	267 x 219		3.0 x 3.0		125	379	6.10
10 x 10	250 x 250	267 x 267		3.0 x 3.0		155	447	7.90
12 x 5	300 x 125	324 x 133		4.0 x 2.5		85	233	2.60
12 x 6	300 x 150	324 x 159		4.0 x 2.5		95	279	3.80
12 x 7	300 x 175	324 x 194		4.0 x 3.0		110	334	4.90
12 x 8	300 x 200	324 x 219		4.0 x 3.0		125	379	5.80
12 x 10	300 x 250	324 x 267		4.0 x 3.0		155	447	10.00
12 x 12	300 x 300	324 x 324		4.0 x 4.0		185	560	16.50

## Saddle Type Connections (continued)

Size			Wall Thickness		Height	Length	Theoretical Weight	
NPS	DN	OD <sub>1</sub> mm	OD <sub>2</sub> mm	S <sub>1</sub> mm	S <sub>2</sub> mm	h mm	L mm	kg / piece
14 x 6	350 x 150	368 x 159		4.0 x 2.5		95	279	3.60
14 x 7	350 x 175	368 x 194		4.0 x 3.0		110	334	4.90
14 x 8	350 x 200	368 x 219		4.0 x 3.0		125	379	5.80
14 x 10	350 x 250	368 x 276		4.0 x 3.0		155	447	9.70
14 x 12	350 x 300	368 x 324		4.0 x 4.0		185	560	16.80
14 x 14	350 x 350	368 x 368		4.0 x 4.0		200	613	25.00
16 x 6	400 x 150	419 x 159		4.0 x 2.5		95	279	3.65
16 x 7	400 x 175	419 x 194		4.0 x 3.0		110	334	4.90
16 x 8	400 x 200	419 x 219		4.0 x 3.0		125	379	5.80
16 x 10	400 x 250	419 x 267		4.0 x 3.0		155	447	9.70
16 x 12	400 x 300	419 x 324		4.0 x 4.0		185	560	16.80
16 x 14	400 x 350	419 x 368		4.0 x 4.0		200	613	25.00
16 x 16	400 x 400	419 x 419		4.0 x 4.0		225	680	33.00
18 x 6	450 x 150	457 x 159		4.5 x 2.5		95	279	3.60
18 x 7	450 x 175	457 x 194		4.5 x 3.0		110	334	4.90
18 x 8	450 x 200	457 x 219		4.5 x 3.0		125	379	5.80
18 x 10	450 x 250	457 x 267		4.5 x 3.0		155	447	9.70

Other dimensions on request.

Size			Wall Thickness		Height	Length	Theoretical Weight	
NPS	DN	OD <sub>1</sub> mm	OD <sub>2</sub> mm	S <sub>1</sub> mm	S <sub>2</sub> mm	h mm	L mm	kg / piece
18 x 12	450 x 300	457 x 324		4.5 x 4.0		185	279	16.80
18 x 14	450 x 350	457 x 368		4.5 x 4.0		200	613	25.00
18 x 16	450 x 400	457 x 419		4.5 x 4.0		225	680	33.00
18 x 18	450 x 450	457 x 457		4.5 x 4.5		250	800	41.00
20 x 6	500 x 150	508 x 159		5.0 x 2.5		95	279	5.40
20 x 7	500 x 175	508 x 194		5.0 x 3.0		110	334	6.50
20 x 8	500 x 200	508 x 219		5.0 x 3.0		125	379	7.70
20 x 10	500 x 250	508 x 267		5.0 x 3.0		155	447	9.70
20 x 12	500 x 300	508 x 324		5.0 x 4.0		185	560	16.80
20 x 14	500 x 350	508 x 368		5.0 x 4.0		200	613	25.00
20 x 16	500 x 400	508 x 419		5.0 x 4.0		225	680	33.00
20 x 18	500 x 450	508 x 457		5.0 x 4.5		250	800	41.00
20 x 20	500 x 500	508 x 508		5.0 x 5.0		275	880	55.00
24 x 12	600 x 300	610 x 324		5.0 x 4.0		185	560	16.80
24 x 14	600 x 350	610 x 368		5.0 x 4.0		200	613	25.00
24 x 16	600 x 400	610 x 419		5.0 x 4.0		225	680	33.00
24 x 18	600 x 450	610 x 457		5.0 x 4.5		250	800	41.00

Other dimensions on request.



# Reducers

**Specifications:**  
DIN 86089

**Material:**  
OSNA®-10 – copper-nickel

**Type and Construction:**  
Concentric reducers up to and including 14"/368 mm are normally supplied as one-piece and seamless.  
Eccentric reducers up to and including 14"/368 mm are normally supplied as one-piece and seamless.

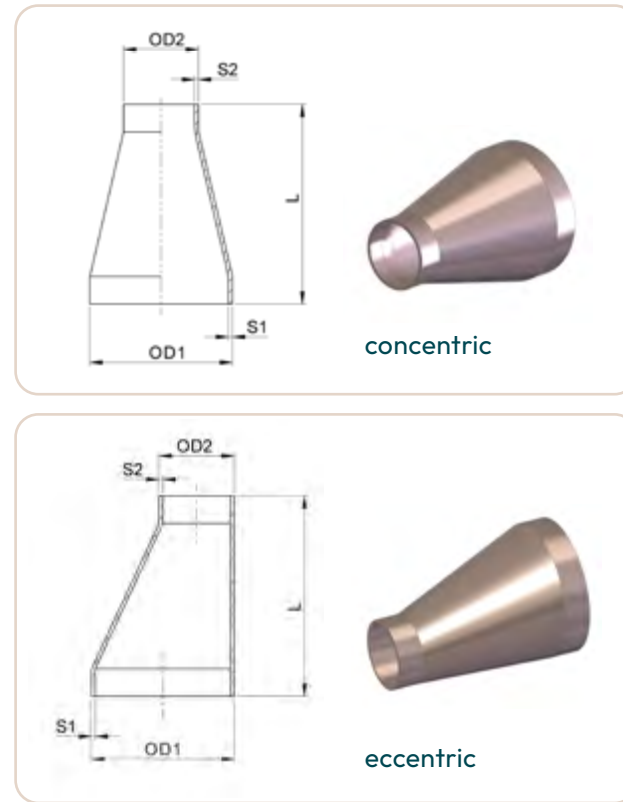

Size		Wall Thickness		Length	Theoretical Weight		
NPS	DN	OD <sub>1</sub> mm	OD <sub>2</sub> mm	S <sub>1</sub> mm	S <sub>2</sub> mm	L mm	kg / piece
½ x ¾	16 x 12	20 x 16		1.0 x 1.0		30	0.01
¾ x ¾	20 x 12	25 x 16		1.5 x 1.0		30	0.02
¾ x ½	20 x 16	25 x 20		1.5 x 1.0		30	0.03
1 x ¾	25 x 12	30 x 16		1.5 x 1.0		35	0.03
1 x ½	25 x 16	30 x 20		1.5 x 1.0		35	0.04
1 x ¾	25 x 20	30 x 25		1.5 x 1.5		35	0.06
1 ¼ x ¾	32 x 12	38 x 16		1.5 x 1.0		50	0.05

Size		Wall Thickness		Length	Theoretical Weight		
NPS	DN	OD <sub>1</sub> mm	OD <sub>2</sub> mm	S <sub>1</sub> mm	S <sub>2</sub> mm	L mm	kg / piece
1 ¼ x ½	32 x 16	38 x 20		1.5 x 1.0		50	0.06
1 ¼ x ¾	32 x 20	38 x 25		1.5 x 1.5		50	0.08
1 ¼ x 1	32 x 25	38 x 30		1.5 x 1.5		50	0.10
1 ½ x ½	40 x 16	44.5 x 20		1.5 x 1.0		80	0.09
1 ½ x ¾	40 x 20	44.5 x 25		1.5 x 1.5		80	0.15
1 ½ x 1	40 x 25	44.5 x 30		1.5 x 1.5		80	0.16
1 ½ x 1 ¼	40 x 32	44.5 x 38		1.5 x 1.5		80	0.17
2 x ¾	50 x 20	57 x 25		1.5 x 1.5		80	0.17
2 x 1	50 x 25	57 x 30		1.5 x 1.5		80	0.18
2 x 1 ¼	50 x 32	57 x 38		1.5 x 1.5		80	0.19
2 x 1 ½	50 x 40	57 x 44.5		1.5 x 1.5		80	0.21
2 ½ x 1	65 x 25	76 x 30		2.0 x 1.5		90	0.28
2 ½ x 1 ¼	65 x 32	76 x 38		2.0 x 1.5		90	0.29
2 ½ x 1 ½	65 x 40	76 x 44.5		2.0 x 1.5		90	0.30
2 ½ x 2	65 x 50	76 x 57		2.0 x 1.5		90	0.31
3 x 1 ¼	80 x 32	89 x 38		2.0 x 1.5		90	0.33
3 x 1 ½	80 x 40	89 x 44.5		2.0 x 1.5		90	0.35
3 x 2	80 x 50	89 x 57		2.0 x 1.5		90	0.37
3 x 2 ½	80 x 65	89 x 76		2.0 x 2.0		90	0.39
4 x 1 ½	100 x 40	108 x 44.5		2.5 x 1.5		100	0.59
4 x 2	100 x 50	108 x 57		2.5 x 1.5		100	0.61
4 x 2 ½	100 x 65	108 x 76		2.5 x 2.0		100	0.63
4 x 3	100 x 80	108 x 89		2.5 x 2.0		100	0.65

# Reducers

Size			Wall Thickness		Length	Theoretical Weight	
NPS	DN	OD <sub>1</sub> mm	OD <sub>2</sub> mm	S <sub>1</sub> mm	S <sub>2</sub> mm	L mm	kg / piece
5 x 2	125 x 50	133 x 57		2.5	1.5	140	1.22
5 x 2 ½	125 x 65	133 x 76		2.5	2.0	140	1.25
5 x 3	125 x 80	133 x 89		2.5	2.0	140	1.23
5 x 4	125 x 100	133 x 108		2.5	2.5	140	1.24
6 x 2 ½	150 x 65	159 x 76		2.5	2.0	150	1.53
6 x 3	150 x 80	159 x 89		2.5	2.0	150	1.54
6 x 4	150 x 100	159 x 108		2.5	2.5	150	1.55
6 x 5	150 x 125	159 x 133		2.5	2.5	150	1.55
7 x 3	175 x 80	194 x 89		3.0	2.0	155	1.94
7 x 4	175 x 100	194 x 108		3.0	2.5	155	2.57
7 x 5	175 x 125	194 x 133		3.0	2.5	155	2.58
7 x 6	175 x 150	194 x 159		3.0	2.5	155	2.59
8 x 4	200 x 100	219 x 108		3.0	2.5	155	2.65

Size			Wall Thickness		Length	Theoretical Weight	
NPS	DN	OD <sub>1</sub> mm	OD <sub>2</sub> mm	S <sub>1</sub> mm	S <sub>2</sub> mm	L mm	kg / piece
8 x 5	200 x 125	219 x 133		3.0	2.5	155	2.54
8 x 6	200 x 150	219 x 159		3.0	2.5	155	2.56
8 x 7	200 x 175	219 x 194		3.0	3.0	155	2.67
10 x 5	250 x 125	267 x 133		3.0	2.5	210	5.10
10 x 6	250 x 150	267 x 159		3.0	2.5	210	5.00
10 x 7	250 x 175	267 x 194		3.0	3.0	210	4.90
10 x 8	250 x 200	267 x 219		3.0	3.0	210	4.80
12 x 5	300 x 125	324 x 133		4.0	2.5	210	6.85
12 x 6	300 x 150	324 x 159		4.0	2.5	210	7.02
12 x 7	300 x 175	324 x 194		4.0	3.0	210	6.98
12 x 8	300 x 200	324 x 219		4.0	3.0	210	6.93
12 x 10	300 x 250	324 x 267		4.0	3.0	210	6.81

# Reducers (continued)

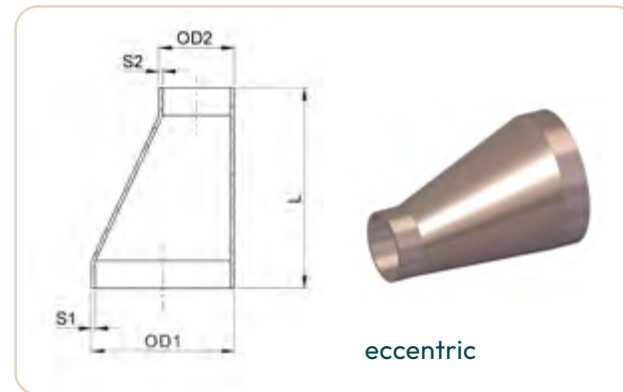
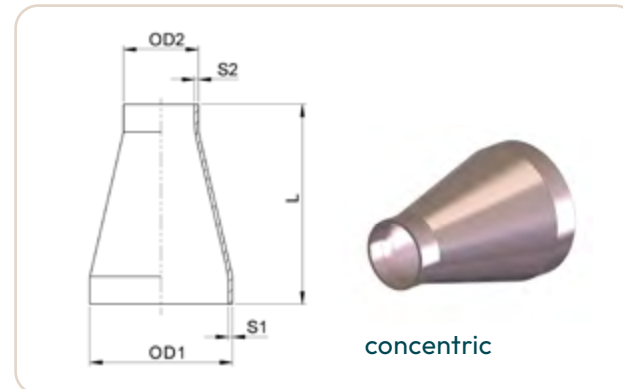

Size		Wall Thickness		Length	Theoretical Weight		
NPS	DN	OD <sub>1</sub> mm	OD <sub>2</sub> mm	S <sub>1</sub> mm	S <sub>2</sub> mm	L mm	kg / piece
14 x 6	350 x 150	368	159	4.0	2.5	300	10.75
14 x 7	350 x 175	368	194	4.0	3.0	300	11.00
14 x 8	350 x 200	368	219	4.0	3.0	300	11.10
14 x 10	350 x 250	368	267	4.0	3.0	300	11.20
14 x 12	350 x 300	368	324	4.0	4.0	300	11.30
16 x 7	400 x 175	419	194	4.0	3.0	325	14.80
16 x 8	400 x 200	419	219	4.0	3.0	325	15.31

Size		Wall Thickness		Length	Theoretical Weight		
NPS	DN	OD <sub>1</sub> mm	OD <sub>2</sub> mm	S <sub>1</sub> mm	S <sub>2</sub> mm	L mm	kg / piece
16 x 10	400 x 250	419	267	4.0	3.0	325	15.93
16 x 12	400 x 300	419	324	4.0	4.0	325	16.77
16 x 14	400 x 350	419	368	4.0	4.0	325	17.68
18 x 8	450 x 200	457	219	4.5	3.0	350	21.40
18 x 10	450 x 250	457	267	4.5	3.0	350	21.90
18 x 12	450 x 300	457	324	4.5	3.0	350	22.70
18 x 14	450 x 350	457	368	4.5	4.0	350	23.20
18 x 16	450 x 400	457	419	4.5	4.0	350	22.70
20 x 10	500 x 250	508	267	5.0	3.0	375	28.70
20 x 12	500 x 300	508	324	5.0	4.0	375	29.50
20 x 14	500 x 350	508	368	5.0	4.0	375	29.70
20 x 16	500 x 400	508	419	5.0	4.0	375	30.10
20 x 18	500 x 450	508	457	5.0	4.5	375	30.90
24 x 14	600 x 350	610	368	5.0	4.0	400	45.70
24 x 16	600 x 400	610	419	5.0	4.0	400	46.50
24 x 18	600 x 450	610	457	5.0	4.5	400	47.40
24 x 20	600 x 500	610	508	5.0	5.0	400	48.20

# FLANGES

## Welding Necks

**Specifications:**  
DIN 86037 -2 compatible with Outer Flanges PN 10, 16

**Material:**  
OSNA®-10 – copper-nickel

**Type and Construction:**  
Weld neck flanges up to and including 12"/ 324 mm are normally supplied as one-piece and seamless.

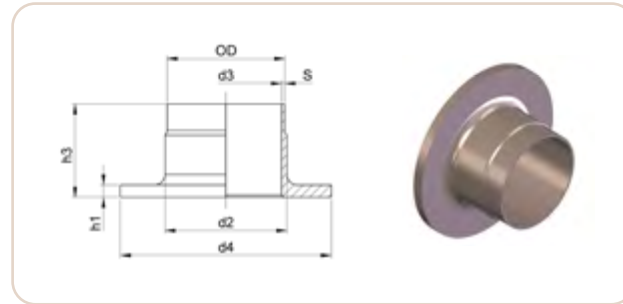

Size			Wall Thickness						Theoretical Weight
NPS	DN	OD mm	S mm	d <sub>2</sub> mm	d <sub>3</sub> mm	d <sub>4</sub> mm	h <sub>1</sub> mm	h <sub>3</sub> mm	kg /piece
½	20	25.0	1.5	27	22	58	5	40	0.15
½	20	25.0	2.0	27	21	58	5	40	0.16
1	25	30.0	1.5	32	27	68	5	40	0.20
1	25	30.0	2.0	32	26	68	5	40	0.21
1¼	32	38.0	1.5	40	35	78	5	40	0.25
1¼	32	38.0	2.0	40	34	78	5	40	0.27
1½	40	44.5	1.5	46.5	41.5	88	6	45	0.36
1½	40	44.5	2.0	46.5	40.5	88	6	45	0.38
2	50	57.0	1.5	59	54	102	6	45	0.45
2	50	57.0	2.0	59	53	102	6	45	0.48

Size			Wall Thickness						Theoretical Weight
NPS	DN	OD mm	S mm	d <sub>2</sub> mm	d <sub>3</sub> mm	d <sub>4</sub> mm	h <sub>1</sub> mm	h <sub>2</sub> mm	kg /piece
2½	65	76	2.0	78	72	122	6	45	0.62
3	80	89	2.0	91	85	138	7	50	0.86
4	100	108	2.5	110	103	158	7	50	1.10
5	125	133	2.5	135.5	128	188	7	50	1.50
6	150	159	2.5	161.5	154	212	9	50	2.00
7	175	194	3.0	197	188	242	9	50	2.40
8	200	219	3.0	222	213	268	9	50	2.70
10	250	267	3.0	270	261	320	9	50	3.40
12	300	324	4.0	327	316	370	11	50	4.60
14	350	368	4.0	371	360	430	11	50	6.30
16	400	419	4.0	422	411	482	12	50	7.50
18	450	457	4.0	460	449	530	12	50	9.00
20	500	508	4.5	511	499	585	12	50	11.00
24	600	610	4.5	613	601	685	14	60	15.00
28	700	711	6.0	714	699	800	14	60	21.00
32	800	813	6.0	816	801	905	14	60	24.00
36	900	914	8.0	918	898	1000	14	60	29.00
40	1000	1016	8.0	1018	1000	1110	14	60	34.00
48	1200	1220	8.0	1223.5	1204	1335	14	60	46.00

Other dimensions on request.

FLANGES

# Outer Flanges

**Specifications:**

DIN 86037, EN 1092-3 (Type 04) PN10, 16

**Material:**

S235JR

**Note:**

Steel flanges will be supplied hot-dip galvanized.

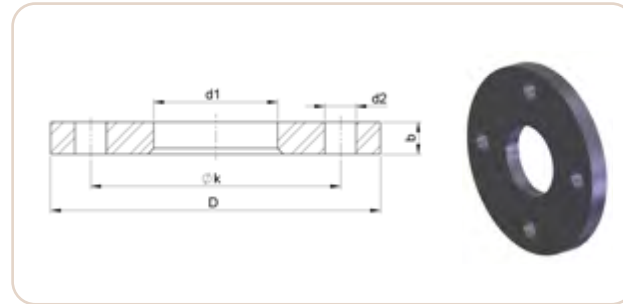

## PN 10

Size									Theoretical Weight
NPS	DN	OD mm	D mm	d <sub>1</sub> mm	b mm	k mm	d <sub>2</sub> mm	Bolt Holes	kg /piece
¾	20	25	105	28	14	75	14	4	0.81
1	25	30	115	33	16	85	14	4	1.11
1¼	32	38	140	41	16	100	18	4	1.64
1½	40	44.5	150	48	16	110 <sup>1</sup>	18	4	1.86
2	50	57	165	62	16	125	18	4	2.20
2½	65	76	185	81	16	145	18	4	2.62
3	80	89	200	94	18	160	18	8	3.32
4	100	108	220	113	18	180	18	8	3.67
5	125	133	250	138	18	210	18	8	4.54
6	150	159	285	164	18	240	22	8	5.60
7	175	194	315	200	22	270	22	8	6.50
8	200	219	340	225	20	295	22	8	7.46
10	250	267	395	278	22	350	22	12	10.30

<sup>1</sup>DIN EN 1092-3:2004-10 and draft DIN EN 1092-3:2022-02 indicate 115 mm by error. The correct value, that can be found e.g. in BS EN 1092-3:2004-03-08 is: 110 mm. We informed the DIN committee already. cunova will deliver flanges with 110 mm only.

Size									Theoretical Weight
NPS	DN	OD mm	D mm	d <sub>1</sub> mm	b mm	k mm	d <sub>2</sub> mm	Bolt Holes	kg /piece
12	300	324	445	331	24	400	22	12	12.00
14	350	368	505	375	24	460	22	16	16.00
16	400	419	565	426	26	515	26	16	20.00
18	450	457	615	465	28	565	26	20	25.00
20	500	508	670	517	30	620	26	20	31.00
24	600	610	780	618	32	725	30	20	40.00
28	700	711	895	720	34	840	30	24	54.00
32	800	813	1015	822	38	950	33	24	76.00
36	900	914	1115	923	42	1050	33	28	92.00
40	1000	1016	1230	1025	46	1160	36	28	120.00
48	1200	1220	1455	1230	50	1380	39	32	170.00

## PN 16

¾ - 6	20 - 150	25 - 159	see PN 10						
7	175	194	315	200	22	270	22	8	7.50
8	200	219	340	225	22	295	22	12	8.00
10	250	267	405	273	24	355	26	12	12.00
12	300	324	460	330	28	410	26	12	16.00
14	350	368	520	374	32	470	26	16	23.00
16	400	419	580	426	36	525	30	16	31.00

Other dimensions on request.



FLANGES

# Composite Blind Flanges

**Specifications:**

EN 1092-3 (Type 05-C) PN 10, 16

**Material:**

OSNA®-10 – copper-nickel  
A105/P245GH EN 10222-2 (flanges)

**Note:**

Steel flanges will be supplied hot-dip galvanized.

DN 10 - DN 175 PN 16  
DN 200 - DN 500 PN 10

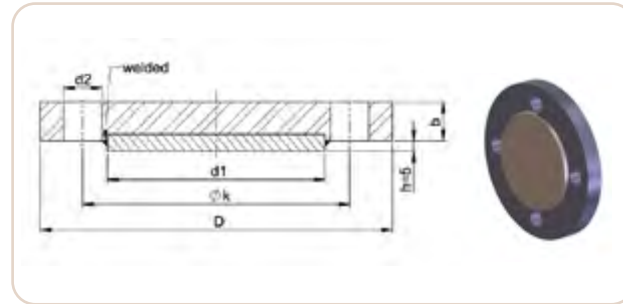

Size									Theoretical Weight
NPS	DN	OD mm	D mm	b mm	k mm	d <sub>1</sub> mm	d <sub>2</sub> mm	Bolt Holes	kg /piece
3/8	10	15	90	14	60	41	14	4	0.69
1/2	15	18	95	14	65	46	14	4	0.78
3/4	20	25	105	14	75	56	14	4	0.99
1	25	30	115	16	85	65	14	4	1.38
1 1/4	32	38	140	16	100	76	18	4	1.99
1 1/2	40	44.5	150	16	115	84	18	4	2.32
2	50	57	165	16	125	99	18	4	2.89
2 1/2	65	76	185	16	145	118	18	4	3.72
3	80	89	200	18	160	132	18	8	4.76
4	100	108	220	18	180	156	18	8	5.94
5	125	133	250	18	210	184	18	8	7.83
6	150	159	285	18	240	211	22	8	10.15
7	175	194	315	22	270	242	22	8	14.97

Size									Theoretical Weight
NPS	DN	OD mm	D mm	b mm	k mm	d <sub>1</sub> mm	d <sub>2</sub> mm	Bolt Holes	kg /piece
8	200	219	340	22	295	266	22	12	17.37
10	250	267	405	24	350	319	26	12	26.64
12	300	324	460	28	400	370	26	12	39.93
14	350	368	520	30	460	429	26	16	54.47
16	400	419	580	36	515	480	30	16	79.52
20	500	508	715	36	650	606	33	20	121.51

Other dimensions on request.

BRAZING FITTINGS

# Couplings, straight

with silver solder  
capillary x capillary ends  
PN up to 63

**Material:**  
OSNA®-10 – copper-nickel

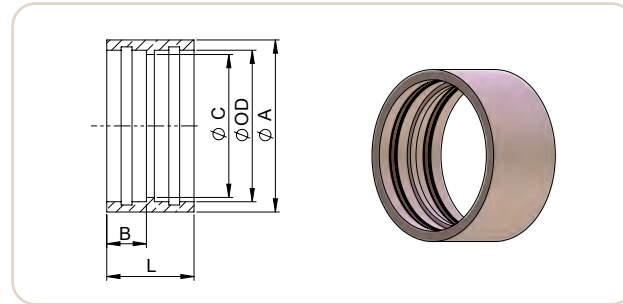

Size							Theoretical Weight
NPS	DN	OD mm	A mm	C mm	L mm	B mm	kg /piece
	4	8	12	6	20	9	0.010
1/8	6	10	15	8	20	9	0.015
1/4	8	12	17	10	20	9	0.020
1/4	10	14	20	12	22	10	0.025
3/8	12	16	22	14	22	10	0.030
1/2	16	20	27	18	22	10	0.045
3/4	20	25	32	22	22	10	0.055
1	25	30	37	27	24	11	0.070
1 1/4	32	38	45	35	32	15	0.120
1 1/4	40	44.5	52	41.5	33	15	0.170
2	50	57	65	54	33	15	0.220
2 1/2	65	76	84	72	45	20	0.400
3	80	89	100	85	55	25	0.570
4	100	108	120	103	65	30	0.690

Other dimensions on request.



BRAZING FITTINGS

# Couplings, reduced

with silver solder  
capillary x capillary ends  
PN up to 63

**Material:**  
OSNA®-10 – copper-nickel

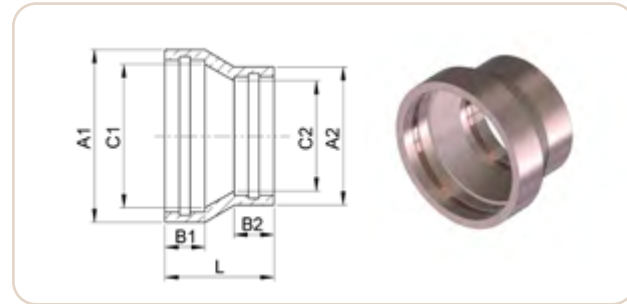

Size									Theoretical Weight
NPS	OD mm	A <sub>1</sub> mm	A <sub>2</sub> mm	C <sub>1</sub> mm	C <sub>2</sub> mm	B <sub>1</sub> mm	B <sub>2</sub> mm	L mm	kg /piece
	10 x 8	15	12	8	6	9	9	22	0.03
	12 x 8	17	12	10	6	9	9	25	0.03
¼ x ¼	12 x 10	17	15	10	8	9	9	21	0.04
	14 x 8	20	12	12	6	10	9	30	0.04
¼ x ½	14 x 10	20	15	12	8	10	9	26	0.04
¾ x ¾	16 x 10	22	15	14	8	10	9	28	0.05
¾ x ¼	16 x 12	22	17	14	10	10	9	27	0.06
½ x ¼	20 x 12	27	17	18	10	10	9	33	0.06
½ x ¾	20 x 16	27	22	18	14	10	10	27	0.08
¾ x ¾	25 x 16	32	22	22	14	10	10	33	0.07
¾ x ½	25 x 20	32	27	22	18	10	10	27	0.09
1 x ¾	30 x 16	37	22	27	14	11	10	35	0.10
1 x ½	30 x 20	37	27	27	18	11	10	31	0.10
1 x ¼	30 x 25	37	32	27	22	11	10	28	0.18

Size									Theoretical Weight
NPS	OD mm	A <sub>1</sub> mm	A <sub>2</sub> mm	C <sub>1</sub> mm	C <sub>2</sub> mm	B <sub>1</sub> mm	B <sub>2</sub> mm	L mm	kg /piece
1 ¼ x ¾	38 x 16	45	22	35	14	15	10	45	0.17
1 ¼ x ½	38 x 20	45	27	35	18	15	10	41	0.16
1 ¼ x ¼	38 x 25	45	32	35	22	15	10	36	0.13
1 ¼ x 1	38 x 30	45	37	35	27	15	11	33	0.21
1 ½ x ¾	44.5 x 16	52	22	41.5	14	15	10	51	0.21
1 ½ x ½	44.5 x 20	52	27	41.5	18	15	10	47	0.21
1 ½ x ¼	44.5 x 25	52	32	41.5	22	15	10	42	0.18
1 ½ x 1	44.5 x 30	52	37	41.5	27	15	11	39	0.24
1 ½ x 1 ¼	44.5 x 38	52	45	41.5	24	15	15	36	0.23
2 x ¾	57 x 16	65	22	54	14	15	10	62	0.28
2 x ½	57 x 20	65	27	54	18	15	10	58	0.29
2 x ¼	57 x 25	65	32	54	22	15	10	54	0.29
2 x 1	57 x 30	65	37	54	27	15	11	50	0.31
2 x 1 ¼	57 x 38	65	45	54	35	15	15	47	0.28
2 x 1 ½	57 x 44.5	65	52	54	41.5	15	15	41	0.28

Other dimensions on request.

BRAZING FITTINGS

# Elbows

with silver solder  
capillary x capillary ends  
PN up to 63

**Material:**  
OSNA®-10 – copper-nickel

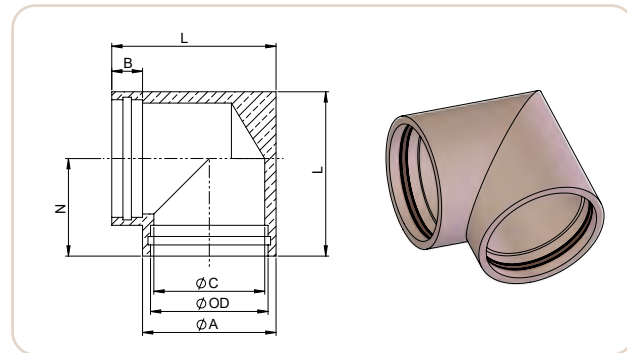

Size							Theoretical Weight
NPS	OD mm	A mm	B mm	C mm	L mm	N mm	kg /piece
1/4	14.0	20	10	12.0	31	21.0	0.068
3/8	16.0	22	10	14.0	31	21.0	0.090
1/2	20.0	27	10	18.0	37	23.5	0.130
3/4	25.0	32	10	22.0	42	26.0	0.185
1	30.0	37	11	27.0	48	29.5	0.260
1 1/4	38.0	45	15	35.0	60	36.5	0.370
1 1/2	44.5	52	15	41.5	67	41.0	0.520
2	57.0	65	15	54.0	80	47.5	0.870

Other dimensions on request.

BRAZING FITTINGS

# Tee Pieces, equal

with silver solder  
capillary x capillary ends  
PN up to 63

**Material:**  
OSNA®-10 – copper-nickel

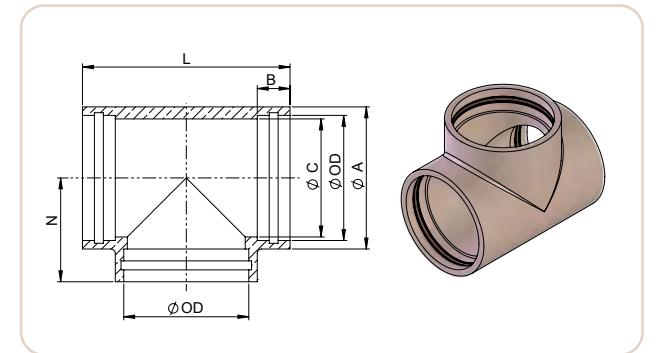

Size							Theoretical Weight	
NPS	DN	OD mm	A mm	B mm	C mm	L mm	N mm	kg /piece
1/4	10	14.0	22	10	12.0	42	21.0	0.06
3/8	13	16.0	22	10	14.0	42	21.0	0.08
1/2	16	20.0	27	10	18.0	47	23.5	0.12
3/4	20	25.0	32	10	22.0	52	26.0	0.19
1	25	30.0	37	11	27.0	57	28.5	0.25
1 1/4	32	38.0	45	15	35.0	73	36.5	0.47
1 1/2	40	44.5	52	15	41.5	82	41.0	0.57
2	50	57.0	65	15	54.0	95	47.5	0.86

Other dimensions on request.



BRAZING FITTINGS

# Tee Pieces, reduced

with silver solder  
capillary x capillary ends  
PN up to 63

**Material:**  
OSNA®-10 – copper-nickel

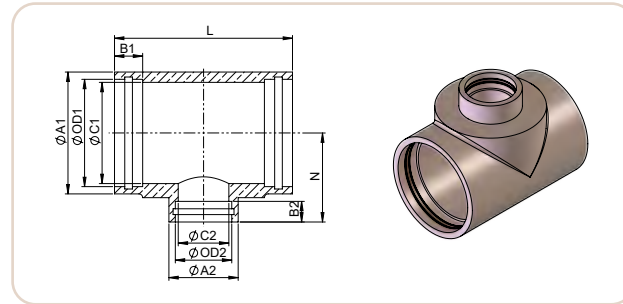

Size											Theoretical Weight
NPS	DN	OD <sub>1</sub> x OD <sub>2</sub> mm	A <sub>1</sub> mm	A <sub>2</sub> mm	C <sub>1</sub> mm	C <sub>2</sub> mm	B <sub>1</sub> mm	B <sub>2</sub> mm	N mm	L mm	kg / piece
¼	10 x 4	14 x 8	22	12	12	6	10	9	21.0	42	0.05
¼ x ⅙	10 x 6	14 x 10	22	15	12	8	10	9	21.0	42	0.06
⅓ x ⅙	12 x 6	16 x 10	22	15	14	8	10	9	21.0	42	0.07
⅓ x ¼	12 x 8	16 x 12	22	17	14	10	10	9	21.0	42	0.08
½ x ¼	16 x 8	20 x 12	27	17	18	10	10	9	23.5	47	0.09
½ x ⅓	16 x 12	20 x 16	27	18	18	14	10	10	23.5	47	0.12
¾ x ⅓	20 x 12	25 x 16	32	22	22	14	10	10	26.0	52	0.14
¾ x ½	20 x 16	25 x 20	32	27	22	18	10	10	26.0	52	0.16
1 x ⅓	25 x 12	30 x 16	37	22	27	14	11	10	28.5	57	0.20
1 x ½	25 x 16	30 x 20	37	27	27	18	11	10	28.5	57	0.25
1 x ¾	25 x 20	30 x 25	37	32	27	22	11	10	28.5	57	0.30
1 ¼ x ⅓	32 x 12	38 x 16	45	22	35	14	15	10	36.5	73	0.40
1 ¼ x ½	32 x 16	38 x 20	45	27	35	18	15	10	36.5	73	0.43

Size											Theoretical Weight
NPS	DN	OD <sub>1</sub> x OD <sub>2</sub> mm	A <sub>1</sub> mm	A <sub>2</sub> mm	C <sub>1</sub> mm	C <sub>2</sub> mm	B <sub>1</sub> mm	B <sub>2</sub> mm	N mm	L mm	kg / piece
1 ¼ x ¾	32 x 20	38 x 25	45	32	35.0	22	15	10	36.5	73	0.43
1 ¼ x 1	32 x 25	38 x 30	45	37	35.0	27	15	11	36.5	73	0.43
1 ½ x ⅝	40 x 12	44.5 x 16	52	22	41.5	14	15	10	41.0	82	0.51
1 ½ x ½	40 x 16	44.5 x 20	52	27	41.5	18	15	10	41.0	82	0.53
1 ½ x ¾	40 x 20	44.5 x 25	52	32	41.5	22	15	10	41.0	82	0.54
1 ½ x 1	40 x 25	44.5 x 30	52	37	41.5	27	15	11	41.0	82	0.57
1 ½ x 1 ¼	40 x 32	44.5 x 38	52	45	41.5	35	15	15	41.0	82	0.59
2 x ½	50 x 16	57 x 20	65	27	54.0	18	15	10	47.5	95	0.65
2 x ¾	50 x 20	57 x 25	65	32	54.0	22	15	10	47.5	95	0.70
2 x 1	50 x 25	57 x 30	65	37	54.0	27	15	11	47.5	95	0.75
2 x 1 ¼	50 x 32	57 x 38	65	45	54.0	35	15	15	47.5	95	0.80
2 x 1 ½	50 x 40	57 x 44.5	65	52	54.0	41.5	15	15	47.5	95	0.86



BRAZING FITTINGS  
**End Caps**

with silver solder  
 capillary ends  
 PN up to 63

**Material:**  
 OSNA®-10 – copper-nickel

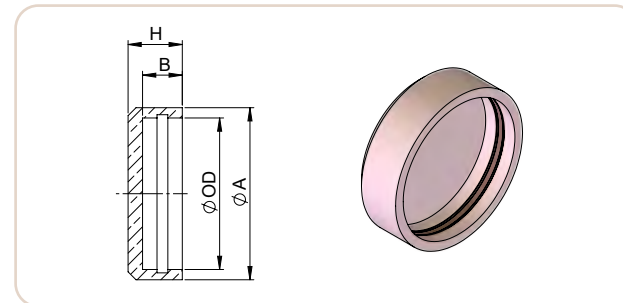

Size						Theoretical Weight
NPS	DN	OD mm	A mm	B mm	H mm	kg / piece
¼	10	14.0	20	10	14.0	0.030
⅜	12	16.0	22	10	14.0	0.040
½	16	20.0	27	10	14.5	0.055
¾	20	25.0	32	10	15.0	0.070
1	25	30.0	37	11	16.0	0.085
1¼	32	38.0	45	15	20.0	0.135
1½	40	44.5	52	15	20.5	0.195
2	50	57.0	65	15	20.5	0.225

Other dimensions on request.

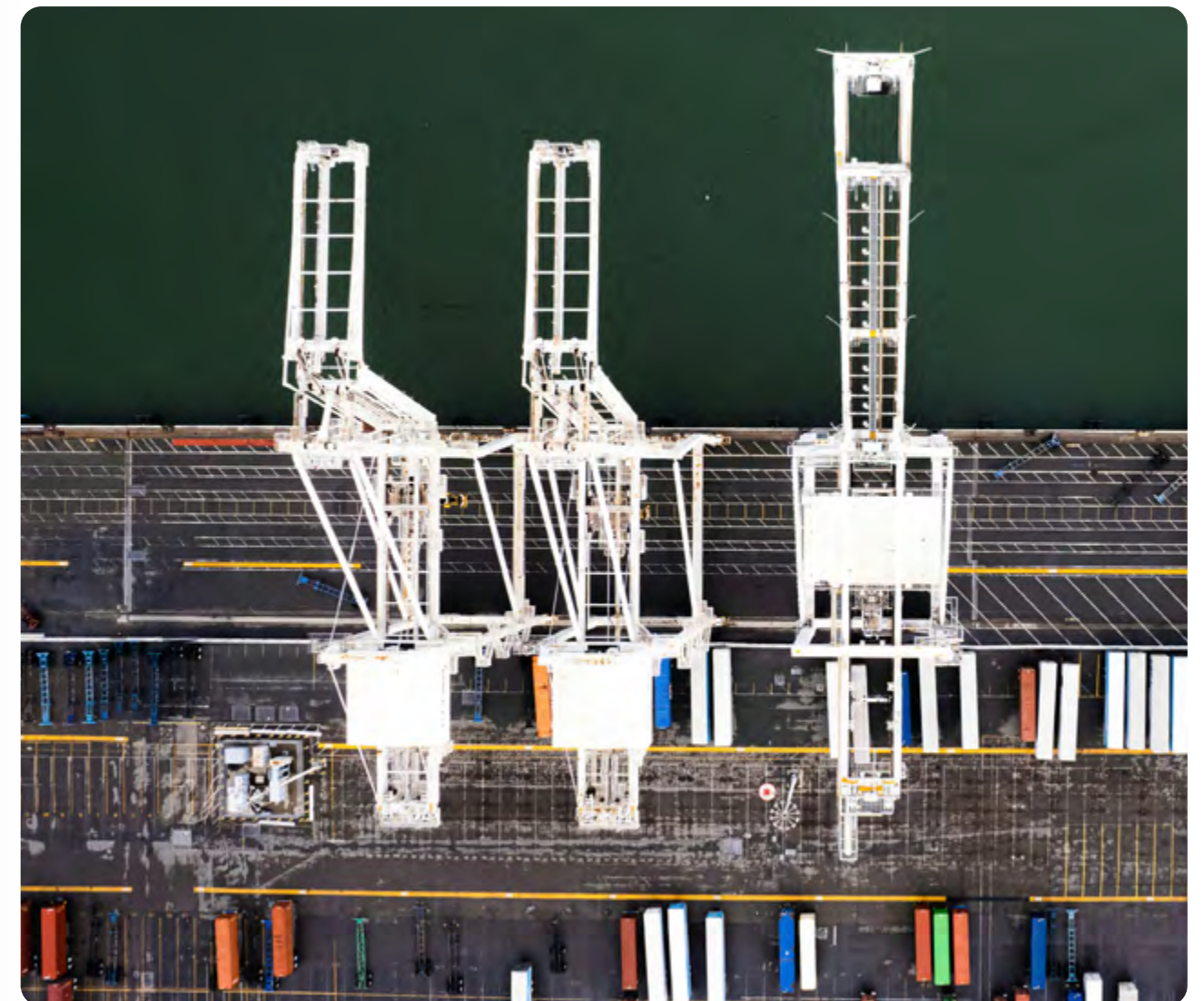

BRAZING FITTINGS

# Straight Male Connectors

**E (male BSP thread)**  
capillary ends x male thread

**Material:**  
OSNA®-10 – copper-nickel

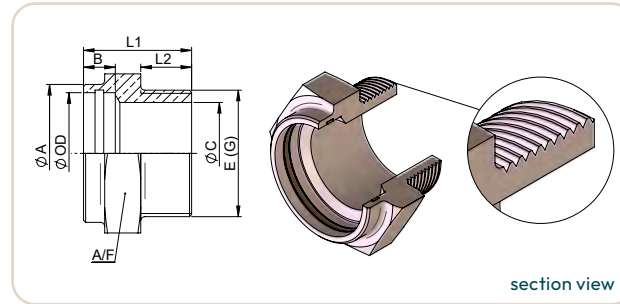

Size								Theoretical Weight
NPS	OD mm x E"	A mm	B mm	C mm	L <sub>1</sub> mm	L <sub>2</sub> mm	A/F mm	kg /piece
¼ x ½	14 x ½	20	10	12	30	18	22	0.06
¼ x ¾	14 x ¾	20	10	12	33	18	30	0.12
¼ x 1	14 x 1	20	10	12	38	21	36	0.16
⅜ x ¾	16 x ¾	22	10	14	29	15	22	0.05
⅜ x ½	16 x ½	22	10	14	30	18	22	0.06
⅜ x ¾	16 x ¾	22	10	14	33	18	30	0.12
⅜ x 1	16 x 1	22	10	14	38	21	36	0.06
½ x ½	20 x ½	27	10	18	33	18	27	0.09
½ x ¾	20 x ¾	27	10	18	34	18	30	0.13
½ x 1	20 x 1	27	10	18	39	21	36	0.23
½ x 1 ¼	20 x 1 ¼	27	10	18	43	22	46	0.39
¾ x ¾	25 x ¾	32	10	22	35	18	32	0.13
¾ x 1	25 x 1	32	10	22	39	21	36	0.20
¾ x 1 ¼	25 x 1 ¼	32	10	22	43	22	46	0.41

Size								Theoretical Weight
NPS	OD mm x E"	A mm	B mm	C mm	L <sub>1</sub> mm	L <sub>2</sub> mm	A/F mm	kg /piece
¾ x 1 ½	25 x 1 ½	32	10	22	44	22	50	0.49
1 x ¾	30 x ¾	37	11	27	38	18	41	0.19
1 x 1	30 x 1	37	11	27	41	21	41	0.29
1 x 1 ¼	30 x 1 ¼	37	11	27	44	22	46	0.24
1 x 1 ½	30 x 1 ½	37	11	27	45	22	50	0.25
1 ¼ x ¾	38 x ¾	45	15	35	44	18	46	0.26
1 ¼ x 1	38 x 1	45	15	35	44	21	46	0.26
1 ¼ x 1 ¼	38 x 1 ¼	45	15	35	45	22	46	0.41
1 ¼ x 1 ½	38 x 1 ½	45	15	35	46	22	50	0.45
1 ½ x 1	44.5 x 1	52	15	41.5	47	21	55	0.49
1 ½ x 1 ¼	44.5 x 1 ¼	52	15	41.5	48	22	55	0.56
1 ½ x 1 ½	44.5 x 1 ½	52	15	41.5	48	22	55	0.60
1 ½ x 2	44.5 x 2	52	15	41.5	51	22	65	0.93
2 x 1 ¼	57 x 1 ¼	65	15	54	51	22	65	0.77
2 x 1 ½	57 x 1 ½	65	15	54	51	22	65	0.80
2 x 2	57 x 2	65	15	54	51	22	65	0.96
2 x 2 ½	57 x 2 ½	65	15	54	60	28	75	1.57

Other dimensions on request.

# Straight Female Connectors

**E (male BSP thread)**  
capillary ends x female thread

**Material:**  
OSNA®-10 – copper-nickel

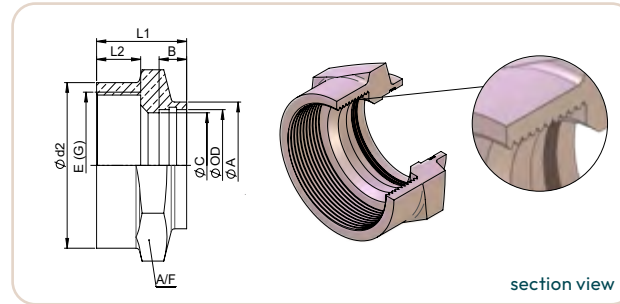

Size									Theoretical Weight
NPS	OD mm x E"	A mm	B mm	C mm	d <sub>2</sub> mm	L <sub>1</sub> mm	L <sub>2</sub> mm	A/F mm	kg / piece
1/4 x 1/2	14 x 1/2	20	10	12	27	32	14	27	0.06
1/4 x 3/4	14 x 3/4	20	10	12	32	34	14	32	0.09
1/4 x 1	14 x 1	20	10	12	40	38	17	41	0.16
3/8 x 3/8	16 x 3/8	22	10	14	21.5	28	11	22	0.05
3/8 x 1/2	16 x 1/2	22	10	14	27	31	14	27	0.07
3/8 x 3/4	16 x 3/4	22	10	14	32	33	14	32	0.10
3/8 x 1	16 x 1	22	10	14	40	38	17	41	0.17
1/2 x 1/2	20 x 1/2	27	10	18	27	28	14	27	0.08
1/2 x 3/4	20 x 3/4	27	10	18	32	32	14	32	0.11
1/2 x 1	20 x 1	27	10	18	40	37	17	41	0.18
1/2 x 1 1/4	20 x 1 1/4	27	10	18	49	40	18	50	0.25
3/4 x 3/4	25 x 3/4	32	10	22	32	31	14	32	0.10
3/4 x 1	25 x 1	32	10	22	40	35	17	41	0.20
3/4 x 1 1/4	25 x 1 1/4	32	10	22	49	39	18	50	0.27

Size									Theoretical Weight
NPS	OD mm x E"	A mm	B mm	C mm	d <sub>2</sub> mm	L <sub>1</sub> mm	L <sub>2</sub> mm	A/F mm	kg / piece
3/4 x 1 1/2	25 x 1 1/2	32	10	22	55	41	18	55	0.33
1 x 3/4	30 x 3/4	37	11	27	32	31	14	41	0.17
1 x 1	30 x 1	37	11	27	40	35	17	41	0.20
1 x 1 1/4	30 x 1 1/4	37	11	27	49	38	18	50	0.22
1 x 1 1/2	30 x 1 1/2	37	11	27	55	40	18	55	0.35
1 1/4 x 3/4	38 x 3/4	45	15	35	32	39	14	46	0.28
1 1/4 x 1	38 x 1	45	15	35	40	39	17	46	0.31
1 1/4 x 1 1/4	38 x 1 1/4	45	15	35	49	40	18	50	0.36
1 1/4 x 1 1/2	38 x 1 1/2	45	15	35	55	42	18	55	0.37
1 1/2 x 1	44.5 x 1	52	15	41.5	40	43	17	55	0.35
1 1/2 x 1 1/4	44.5 x 1 1/4	52	15	41.5	49	39	18	55	0.40
1 1/2 x 1 1/2	44.5 x 1 1/2	52	15	41.5	55	40	18	55	0.43
1 1/2 x 2	44.5 x 2	52	15	41.5	70	43	18	70	0.60
2 x 1 1/4	57 x 1 1/4	65	15	54	49	45	18	65	0.50
2 x 1 1/2	57 x 1 1/2	65	15	54	55	40	18	65	0.55
2 x 2	57 x 2	65	15	54	70	40	18	70	0.65
2 x 2 1/2	57 x 2 1/2	65	15	54	85	49	24	85	0.80

Other dimensions on request.

MISCELLANEOUS

# Hexagon Head Screw Plugs

**Specification:**  
DIN 910

**Material:**  
OSNA®-10 – copper-nickel

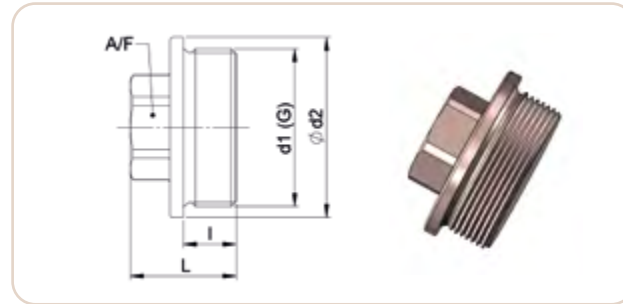

Size					Theoretical Weight
d <sub>1</sub> (thread) G"	d <sub>2</sub> mm	l mm	L mm	A/F mm	kg /piece
G 1/8	14	8	17	10	0.014
G 1/4	18	8	17	13	0.023
G 3/8	18	12	21	13	0.027
G 1/2	22	8	17	17	0.037
G 5/8	22	12	21	17	0.043
G 3/4	26	10	22	19	0.066
G 7/8	26	14	26	19	0.076
G 1	32	12	26	24	0.124
G 1 1/8	32	16	30	24	0.144
G 1 1/4	39	16	32	27	0.221
G 1 3/8	44	16	32	27	0.270
G 1 1/2	49	16	33	30	0.340
G 1 3/4	55	16	33	30	0.425
G 2	62	20	40	36	0.649
G 2 1/4	68	20	40	36	0.788

Other dimensions on request.

MISCELLANEOUS

# Welding Ends

**Material:**  
OSNA®-10 – copper-nickel

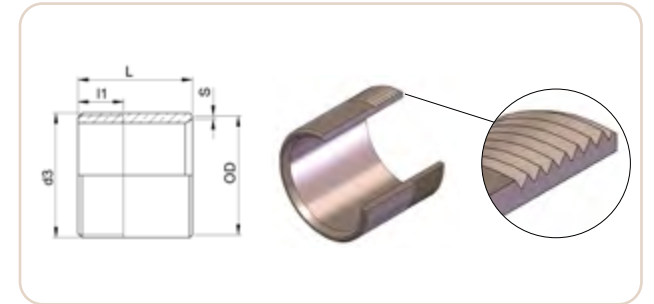

Size						Theoretical Weight	
NPS	DN	OD mm	S mm	d <sub>3</sub> (thread) G	L mm	l <sub>1</sub> mm	kg /piece
1/2	16	20.0	1	G 1/2	35	15	0.03
3/4	20	25.0	1.5	G 3/4	40	15	0.05
1	25	30.0	1.5	G 1	40	19	0.10
1 1/4	32	38.0	1.5	G 1 1/4	50	20	0.19
1 1/2	40	44.5	1.5	G 1 1/2	50	20	0.21
2	50	57.0	1.5	G 2	55	22	0.29
2 1/2	65	76.0	2	G 2 1/2	60	27	0.38
3	80	89.0	2	G 3	65	28	0.50

Other dimensions on request.



MISCELLANEOUS  
Sockets

**Specification:**  
DIN 86103 (Form B),  
PN 40 up to 225°C

**Material:**  
OSNA®-10 – copper-nickel

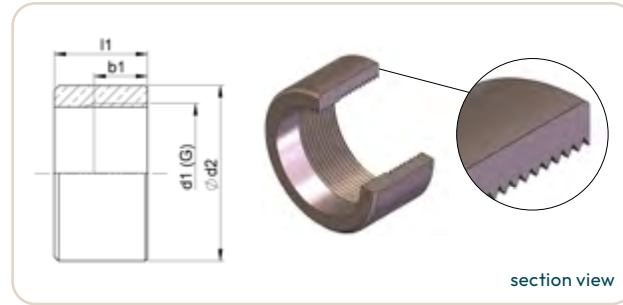

Size				Theoretical Weight
d <sub>1</sub> (thread) inch	d <sub>2</sub> mm	b <sub>1</sub> mm	l <sub>1</sub> mm	kg / piece
G ¼	20	12	20	0.030
G ⅜	25	12	20	0.050
G ½	30	14	25	0.070
G ½	30	14	50	0.150
G ½	30	14	75	0.255
G ½	30	14	100	0.380
G ½	30	14	125	0.470
G ¾	38	16	25	0.120
G ¾	38	16	50	0.240
G ¾	38	16	75	0.445
G ¾	38	16	100	0.550
G ¾	38	16	125	0.700
G 1	45	18	25	0.160
G 1	45	18	50	0.320

Size				Theoretical Weight
d <sub>1</sub> (thread) inch	d <sub>2</sub> mm	b <sub>1</sub> mm	l <sub>1</sub> mm	kg / piece
G 1	45	18	75	0.545
G 1	45	18	100	0.700
G 1	45	18	125	0.950
G 1 ¼	57	20	30	0.250
G 1 ½	62	22	30	0.330
G 2	75	23	40	0.680

Other dimensions on request.

MISCELLANEOUS

# Unions

with silver solder capillary x capillary ends  
equipped with sealing ring  
PN up to 63

**Material:**  
OSNA®-10 – copper-nickel  
Nut: Brass  
Ring sealing: Elastomer FPM

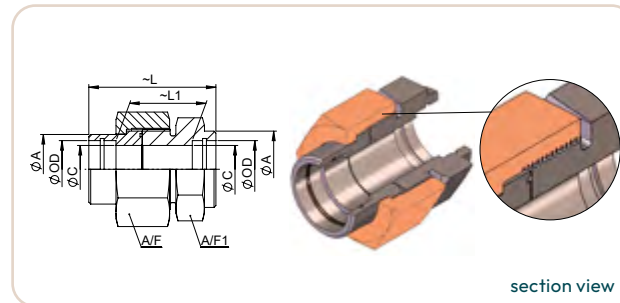

section view

Outside Diameter of Pipe								Theoretical Weight
NPS	OD mm	A mm	C mm	$\sim L$ mm	$\sim L_1$ mm	A/F mm	A/F <sub>1</sub> mm	kg / piece
1/4	14	20	12	50	30	32	27	0.18
3/8	16	22	14	52	32	36	32	0.24
1/2	20	27	18	58	38	41	36	0.31
3/4	25	32	22	61	41	46	41	0.44
1	30	37	27	67	45	50	46	0.45
1 1/4	38	45	35	79	42	60	55	0.73
1 1/2	44.5	52	41.5	80	50	70	60	1.08
2	57	65	54	93	63	85	80	1.54

MISCELLANEOUS

# Male Unions

with silver solder capillary x capillary ends  
equipped with sealing ring  
PN up to 63

**Material:**  
OSNA®-10 – copper-nickel  
Nut: Brass  
Ring sealing: Elastomer FPM

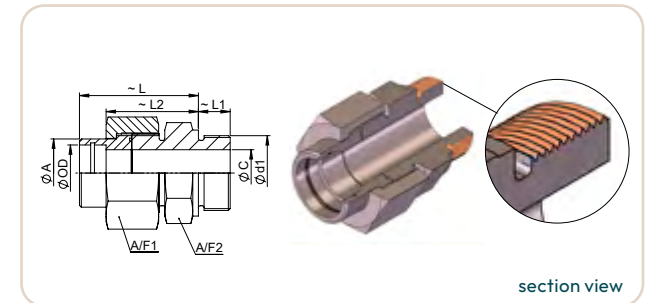

section view

Outside Diameter of Pipe									Theoretical Weight	
NPS	OD mm x G"	A mm	C mm	d <sub>1</sub> (Thread) G"	$\sim L$ mm	L <sub>1</sub> mm	L <sub>2</sub> mm	A/F <sub>1</sub> mm	A/F <sub>2</sub> mm	kg / piece
1/4	14 x 1/2"	20	12	G 5/8"	49	14	39	32	32	0.25
3/8	16 x 3/4"	22	14	G 3/4"	50	16	40	36	32	0.35
1/2	20 x 1"	27	18	G 1"	56	18	46	41	41	0.53
3/4	25 x 1"	32	22	G 1"	57	18	47	46	41	0.72
1	30 x 1 1/4"	37	27	G 1 1/4"	63	20	52	50	50	0.78
1 1/4	38 x 1 1/2"	45	35	G 1 1/2"	71	22	56	60	55	0.90
1 1/2	44.5 x 1 3/4"	52	41	G 1 3/4"	76	24	61	70	65	1.15
2	57 x 2 1/2"	65	54	G 2 1/2"	87	30	72	85	85	1.36

MISCELLANEOUS

# Male Unions, reduced

with silver solder capillary x capillary ends  
equipped with sealing ring  
PN up to 63

**Material:**  
OSNA®-10 – copper-nickel  
Nut: Brass  
Ring sealing: Elastomer FPM

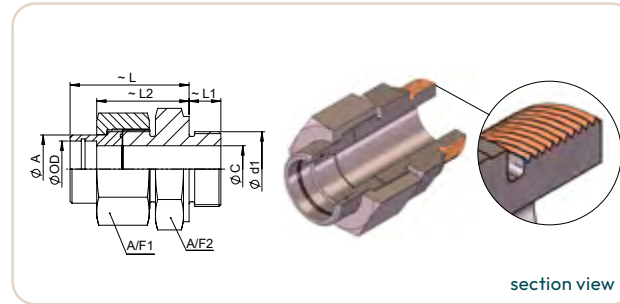

Outside Diameter of Pipe										Theoretical Weight
NPS	OD mm x G"	A mm	C mm	d <sub>1</sub> (Thread) G"	~L mm	L <sub>1</sub> mm	L <sub>2</sub> mm	A/F <sub>1</sub> mm	A/F <sub>2</sub> mm	kg / piece
1/4	14 x 3/8	20	12	G x 3/8	47	12	36	32	27	
1/4	14 x 1/2	20	12	G x 1/2	47	14	37	32	27	0.24
1/4	14 x 3/4	20	12	G x 3/4	49	16	39	32	32	
1/4	14 x 1	20	12	G x 1	52	18	42	32	41	
3/8	16 x 1/2	22	10	G x 1/2	50	14	40	36	32	0.31
3/8	16 x 3/4	22	12	G x 3/4	50	14	40	36	32	
3/8	16 x 1 1/4	22	14	G x 1	53	18	43	36	41	
3/8	16 x 1 1/2	22	14	G x 1 1/4	56	20	46	36	50	
1/2	20 x 5/8	27	12	G x 5/8	54	14	44	41	36	
1/2	20 x 3/4	27	14	G x 3/4	54	16	44	41	36	0.45
1/2	20 x 1 1/4	27	18	G x 1 1/4	59	20	49	41	50	
1/2	20 x 1 1/2	27	18	G x 1 1/2	61	22	51	41	55	
3/4	25 x 3/8	32	12	G x 3/8	56	14	46	46	41	

Outside Diameter of Pipe										Theoretical Weight
NPS	OD mm x G"	A mm	C mm	d <sub>1</sub> (Thread) G"	~L mm	L <sub>1</sub> mm	L <sub>2</sub> mm	A/F <sub>1</sub> mm	A/F <sub>2</sub> mm	kg / piece
3/4	25 x 3/4	32	14	G x 3/4	56	16	46	46	41	0.59
3/4	25 x 1 1/4	32	22	G x 1 1/4	60	20	50	46	50	
3/4	25 x 1 1/2	32	22	G x 1 1/2	62	22	52	46	55	
1	30 x 3/4	37	14	G x 3/4	61	16	50	50	46	
1	30 x 1	37	22	G x 1	62	18	51	50	46	0.72
1	30 x 1 1/2	37	27	G x 1 1/2	65	22	54	50	55	
1	30 x 1 3/4	37	27	G x 1 3/4	68	24	57	50	65	
1 1/4	38 x 3/4	45	14	G x 3/4	70	16	55	60	55	
1 1/4	38 x 1	45	22	G x 1	71	18	56	60	55	1.00
1 1/4	38 x 1 1/4	45	27	G x 1 1/4	71	20	56	60	55	1.07
1 1/4	38 x 1 1/2	45	35	G x 1 1/2	74	24	59	60	65	
1 1/2	44.5 x 1	52	22	G x 1	74	18	59	70	60	
1 1/2	44.5 x 1 1/4	52	27	G x 1 1/4	74	20	59	70	60	
1 1/2	44.5 x 1 1/2	52	35	G x 1 1/2	74	22	59	70	60	1.23
1 1/2	44.5 x 2	52	41	G x 2	77	24	62	70	70	1.57
2	57 x 1 1/4	65	27	G x 1 1/4	83	20	69	85	80	
2	57 x 1 1/2	65	35	G x 1 1/2	83	22	69	85	80	
2	57 x 1 3/4	65	41	G x 1 3/4	83	24	69	85	80	
2	57 x 2	65	48	G x 2	83	24	69	85	80	2.05

Other dimensions on request.

## cunova - QualityManagement

cunova is committed to the continuous improvement of all our business and production processes in terms of efficiency, effectiveness and reliability as regards their organisation, technological aspects and staff management.

The aim of our commitment is to increase the satisfaction of all stakeholders.

We are constantly engaged in:

- creating products of outstanding quality
- preventing errors and defects
- minimising the costs associated with errors and inefficiencies
- preventing the waste of resources
- establishing safe production conditions to protect both our employees and the environment

We aim for excellence by means of transparent management systems designed to satisfy the requirements of our clients together with the demands of the market and technology.

The quality management systems implemented throughout the cunova Group are fully compliant with the provisions of ISO 9001 as well as, in the case of our automotive industry clients, ISO TS 16 949, and our staff is strongly committed to their implementation at all levels.

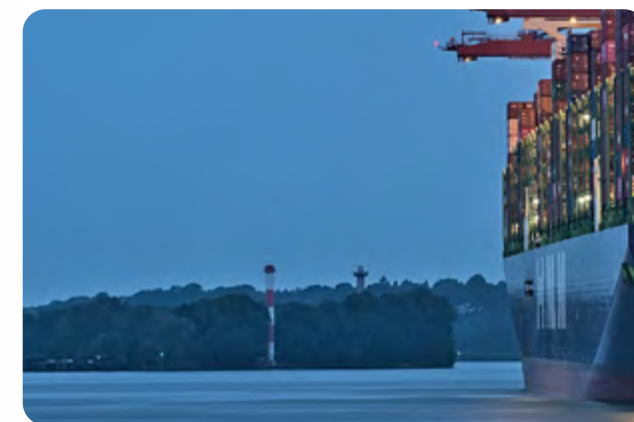



FORMERLY KME  
SPECIAL PRODUCTS  
& SOLUTIONS

**Further information on OSNA®- 10/30 Shipbuilding:**

T +49 541 321-3201  
maritime@cunova.com  
www.cunova.com

cunova GmbH  
Klosterstrasse 29  
49074 Osnabrück  
Germany

® = registered trademark of cunova GmbH

All changes reserved. MC0360623. Owing to limitations in printing technology, the colours reproduced in this brochure should be regarded as approximate equivalents to the colours described. We reserve the right to make changes in keeping with technical developments or to optimise our products. This brochure represents the current and actual version (April 2023). All versions before this date (print or pdf) lose their validity.